

Turbidity Sensor Operation Manual



Table of Contents

Chapter 1 Product Specifications.....	1
Chapter 2 Product Overview.....	3
2.1 Product Information.....	3
2.2 Safety Information.....	3
Chapter 3 Installation.....	4
3.1 Installation of Sensors.....	4
3.2 Connection of Sensor.....	5
Chapter 4 Interface and Operation.....	5
4.1 User Interface.....	5
4.2 Parameter Setting.....	6
Chapter 5 Calibration of Sensor.....	7
Chapter 6 Communication Protocol.....	8
Chapter 7 Maintenance.....	10
7.1 Sensor Cleaning.....	10
7.2 Inspection on the Damage of Sensor.....	10
7.3 Sensor Blade Replacement.....	10

Chapter 1 Product Specifications

Specifications	Details
Size	Diameter 60mm* Length 256mm
Weight	1.65 KG
Main Materials	Main Body:SUS316L (Ordinary Version),Titanium Alloy (Seawater Version) Upper and Lower Cover: PVC Cable: PVC
Waterproof Rate	IP68/NEMA6P
Measurement Range	0.01-100 NTU 、 0.01—4000 NTU
Indication Resolution	Less than $\pm 2\%$ of the measured value, or ± 0.1 NTU Maximax criterion
Pressure Range	≤ 0.4 Mpa
Flow velocity	≤ 2.5 m/s、 8.2ft/s
Storage Temperature	-15~65°C
Environment Temperature	0~45°C
Calibration	Sample Calibration, Slope Calibration
Cable Length	Standard 10-Meter Cable, Max Length: 100 Meters
Power Supply	12 VDC
Warranty Period	1 Year
High Voltage Baffle	Aviation Connector, Cable Connector

External Dimension:

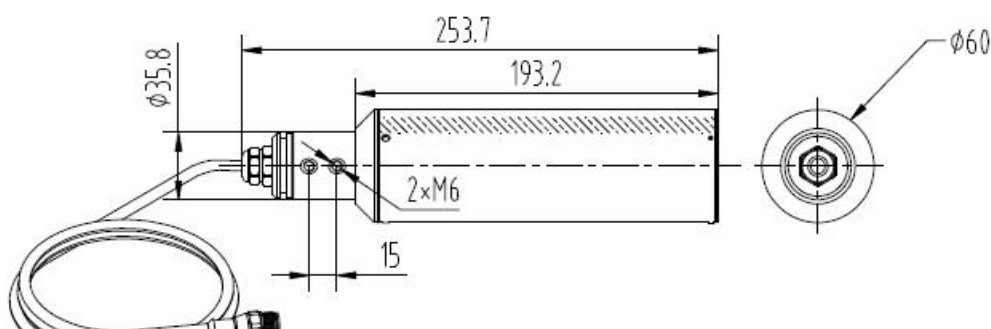

Table 1 Specifications of Turbidity Sensor

Chapter 2 Product Overview

2.1 Product Information

The sensor, based on the infrared absorption scattered light method and combined with the application of ISO7027 method, can guarantee the continuous and accurate detection of turbidity. Based on ISO7027, infrared double scattering light technology will not be affected by chroma for the measurement of turbidity value. According to the usage environment, self-cleaning function can be equipped with. It assures the stability of data and reliability of performance; with the built-in self-diagnosis function, it can make sure the accurate data be delivered; besides, the installation and calibration is quite simple.

The product is widely used in sewage plant, water plant, water station, surface water, farming, industry and other fields.

2.2 Safety Information

Please read this manual completely before opening the package, installing or using. Otherwise it may cause personal injury to the operator, or cause damage to equipment.

Warning labels

Please read all labels and signs on the instrument, and comply with the security label instructions, otherwise it may cause personal injury or equipment damage.



When this symbol appears in the instrument, please refer to the operation or safety information in the reference manual.



While this symbol indicates an electric shock or risk of death from electric shock.

Please read this manual completely. Pay particular attention to some notes or warnings, etc. To ensure that the protective measures provided by the equipment are not destroyed.

Chapter 3 Installation

3.1 Installation of Sensors

The specific installation steps are as follows:

- Install the 8 (mounting plate) on the railing by the pool with 1 (M8 U-shape clamp) at the sensor mounting position;
- Connect 9 (adapter) to 2 (DN32) PVC pipe by glue, pass the sensor cable through Pvc pipe until the sensor screws into 9 (adapter), and do waterproof treatment;
- Fix 2 (DN32 tube) onto 8 (mounting plate) by 4 (DN42U-shape clamp).

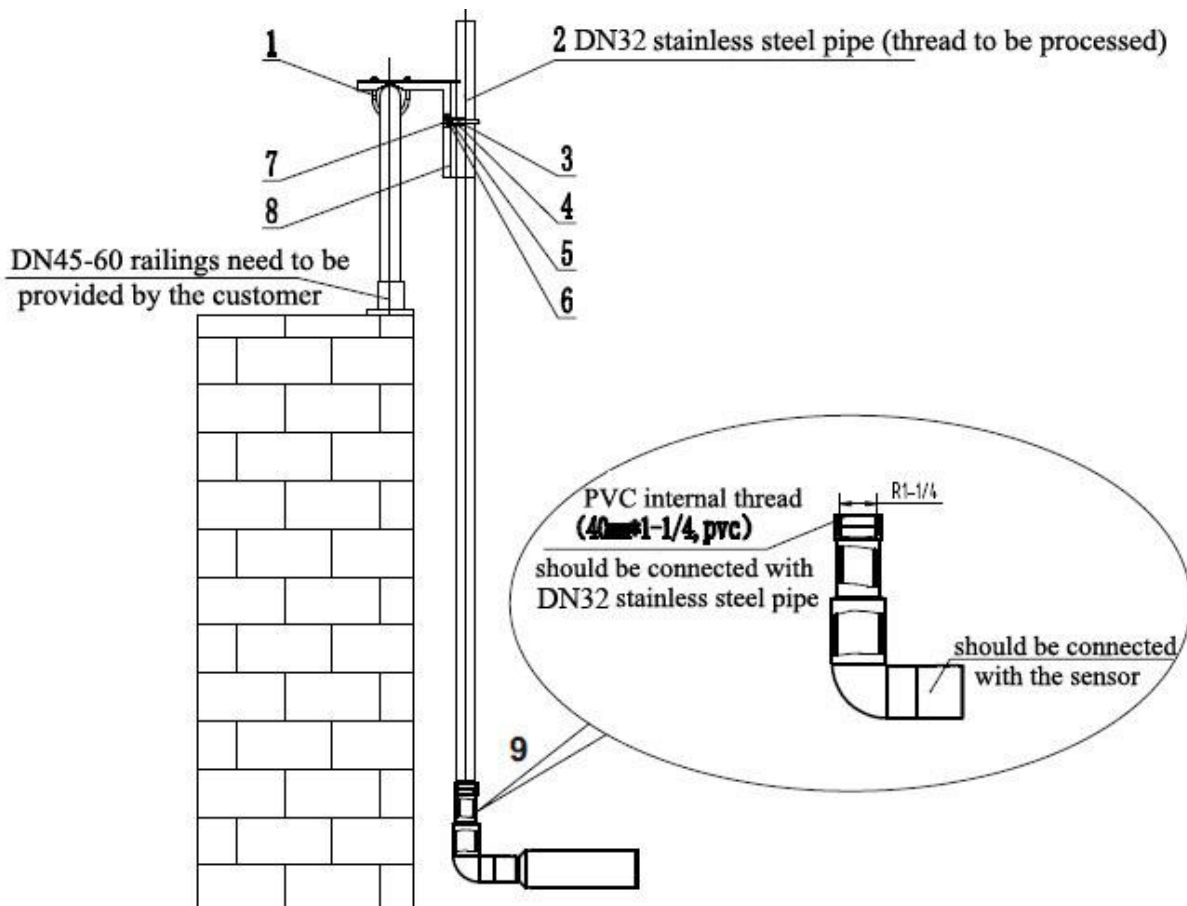

Figure 11 Schematic Diagram on the Installation of Sensor

1-M8U-shape Clamp (DN60)	2- DN32 Pipe (outside diameter 40mm)
3- Hexagon Socket Screw M6*120	4-DN42U-shape Pipe Clip
5- M8 Gasket (8*16*1)	6- M8 Gasket (8*24*2)
7- M8 Spring Shim	8- Mounting Plate
9-Adaptor(Thread to Straight-through)	

3.2 Connection of Sensor

The sensor should be correctly connected by the following definition of wire core:

Serial No.	1	2	3	4
Sensor Cable	Brown	Black	Blue	White
Signal	+12VDC	AGND	RS485 A	RS485 B

Chapter 4 Interface and Operation

4.1 User Interface

① The sensor uses RS485 to USB for connecting to the computer, and then install the CD-ROM software Modbus Poll to the upper computer, double-click and execute the Mbpoll.exe to follow the prompts for installation, eventually, you can enter the user interface.

② If it's the first time, you need to register first. Click "Connection" on the menu bar and select the first line in the drop-down menu. Connection Setup will display the dialog box for registration. As the figure shown below. Copy the attached registration code to the Registration Key and click "OK" to complete the registration.

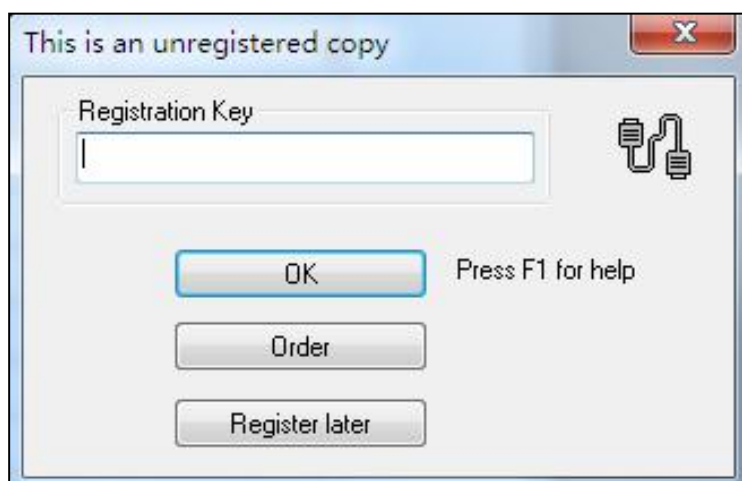

4.2 Parameter Setting

1. Click "Setup" on the menu bar, select "Read / Write Definition", and then click "OK" according to the parameters shown below.

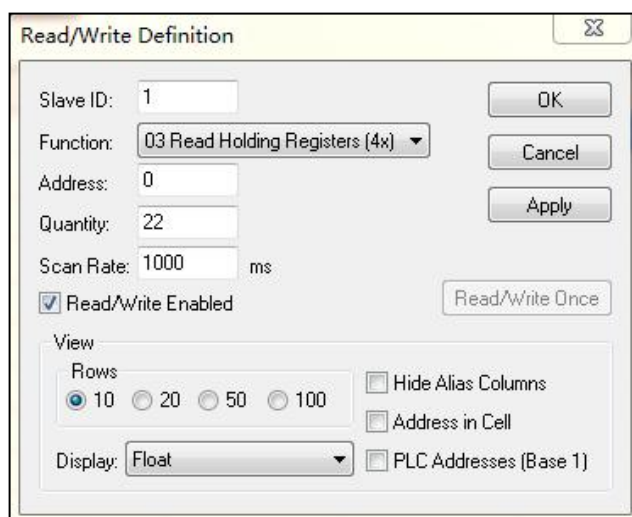

The screenshot shows the "Read/Write Definition" dialog box. The "Slave ID" is set to 1. The "Function" is set to "03 Read Holding Registers (4x)". The "Address" is 0, and the "Quantity" is 22. The "Scan Rate" is 1000 ms. The "Read/Write Enabled" checkbox is checked. The "View" section shows "Rows" set to 10, "Display" set to "Float", and "PLC Addresses (Base 1)" checked. There are buttons for "OK", "Cancel", "Apply", and "Read/Write Once".

Note: The default initial Slave ID is 1, and after the slave address is changed, the new address will be used for communication and the slave address for the next time connection is also the most recently changed address.

2. Click "Connection" on the menu bar, select the first line in the drop-down menu "Connection setup", set it as shown below, and click "OK".

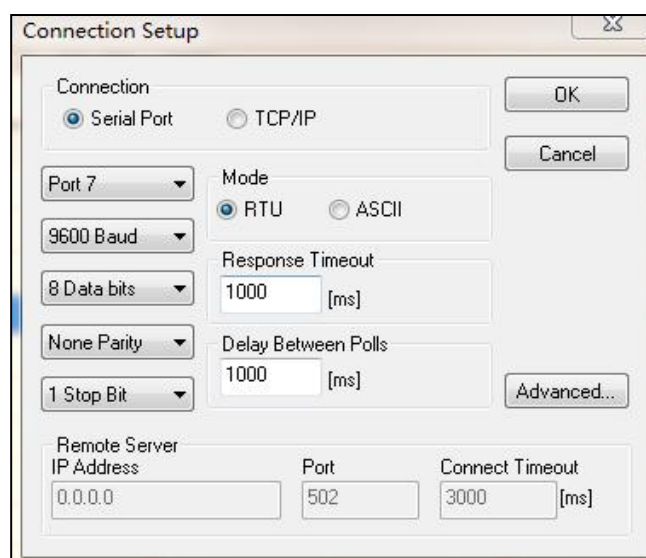

The screenshot shows the "Connection Setup" dialog box. The "Connection" type is "Serial Port". The "Port" is "Port 7", "Mode" is "RTU", "Baud" is "9600 Baud", "Data bits" is "8 Data bits", "Parity" is "None Parity", and "Stop Bit" is "1 Stop Bit". The "Response Timeout" is 1000 ms and "Delay Between Polls" is 1000 ms. There is an "Advanced..." button. The "Remote Server" section shows "IP Address" as 0.0.0.0, "Port" as 502, and "Connect Timeout" as 3000 ms. There are buttons for "OK" and "Cancel".

Note: Port7 means USB representing the COM port on the computer.

Note: If the sensor has been connected as described, and "No Connection" appears on the software "Display status", it means that the connection is failed; remove and replace the USB port or check the USB to RS485 converter, repeat the above procedure until the sensor connection is successful.

Chapter 5 Calibration of Sensor

The turbidity sensor has been calibrated at the factory, and can be calibrated according to the following procedures. It requires the use of turbidity standard solution to calibrate turbidity, and **the specific steps are as follows:**

If there is a large deviation between the measured value and the standard value, the slope of calibration curve needs factor correction.

1. Connect the sensor to the transmitter;
2. Set the relevant parameters and wipe the sensor;
3. Slowly immerse the sensor into the turbidity standard solution;
4. Wait for the value to be stable and record the stable value;
5. Calculate the correction factor. The correction factor equals to the standard solution value divided by the value measured in the fourth step. (Factor = standard solution value / stable value)
6. Enter the calculated correction factor in the corresponding register to complete the calibration.

Note: During the process of calibration, make sure the lens of probe is 15cm far from the bottom of calibration cup and no bubbles in front of the lens, meanwhile, it is recommended to keep the correction cup away from the light.

Chapter 6 Communication Protocol

The sensor is equipped with MODBUS RS485 communication function, please refer to this manual section 3.2 to check the communication wiring . The default baud rate is 9600, the specific MODBUS RTU table is shown in the following table.

MODBUS-RTU	
Baud Rate	4800/9600/19200/38400
Data Bits	8 bit
Parity Check	no
Stop Bit	1bit

Register Name	Address Location	Read/Write	Data Type	Length	Descriptions
Turbidity	13	RW	Int	1	It should be 1, otherwise, it should be changed to 1.
Turbidity Value	0	OR	Float	2	0-Range
Turbidity Factor	4	RW	Float	2	0.1-10
Turbidity Deviation Value	8	RW	Float	2	±100NTU
Brushing Time	11	OR	Int	1	
Manual Brushing Order	20	W	Int	1	Send 66
Automatic Brushing Order	21	W	Int	1	Sending Intervals (1、5、15、30、60 (1h) 、240 (4h) 、720 (12h) 、1440 (1D) 、4320 (3D) 、10080 (7D) unit: min)
Response Time	12	RW	Int	1	1-60s
Probe Humidity	14	OR	Int	1	It is recommended to be less than 10

Turbidity Sensor Operation Manual

Probe Baud Rate	16	RW	Int	1	0 stands for 4800 1 stands for 9600 2 stands for 19200 3 stands for 38400
Probe Slave Address	17	RW	Int	1	1-254
Serial No. 1	18	OR	Int	1	First 4 numbers of Serial No.
Serial No. 2	19	OR	Int	1	Last 4 numbers of Serial No.

Chapter 7 Maintenance

In order to obtain the best measurement results, it is very necessary to maintain the sensor regularly. Maintenance mainly includes cleaning, inspecting damage of the sensor, and periodic calibration. You can also view the sensor's status during maintenance and inspection.

7.1 Sensor Cleaning

Both the two lenses on the sensor need to be cleaned and maintained regularly to ensure the accuracy of the measurement on the basis of actual use. Wash with clean water, then wipe with a cleanser and rag to remove stubborn stains.

7.2 Inspection on the Damage of Sensor

Check the appearance of the sensor to see whether there is damage, if it's damaged, please contact to the after-sales service center in time for replacement to prevent malfunction of sensor caused by water due to the damage.

7.3 Sensor Blade Replacement

It is recommended that the blade of the sensor should be replaced quarterly with a new rubber one, the specific steps are as follows:



- 1.The position of the blade is shown on the left picture;
- 2.Remove the screws on the blade with the corresponding screwdriver;
- 3.Remove the blade, take out the rubber sheet inside, and replace it with a new one;
- 4.Finally put the blade back, and fasten the screw and blade with a screwdriver.